

### ⚡ Specifications

#### Nominal Voltage(V)

12V

#### Nominal Power

15 mins rate: 505W/cell to 1.67V/cell

#### Nominal Capacity

20 hour rate	(6.5A to 10.50V)	130Ah
10 hour rate	(12.35A to 10.50V)	123.5Ah
8 hour rate	(14A to 10.50V)	111.8Ah
5 hour rate	(22.1A to 10.20V)	110.5Ah

#### Weight

Approx. 42kg(92.4Lbs.)

#### Internal Resistance (at 1KHz)

Approx. 4 mΩ

#### Maximum Discharge Current for

5 seconds: 1300A

#### Short Circuit Current (A) IEC 60896-21-22

3183 A

#### Charging Methods at 25°C(77°F)

Maximum Charging Current :	39A
Boost Charging Voltage	14.1 to 14.4V
Boost Charge Time	8-9Hr
Float Charging Voltage	13.5 to 13.65V
Coefficient	-3.0mV/°C/cell

#### Operating Temperature Range

Charge	-15°C(5°F) to 40°C(104°F)
Discharge	-15°C(5°F) to 50°C(122°F)
Storage	-15°C(5°F) to 40°C(104°F)

#### Charge Retention (shelf life) at 20°C(68°F)

1 month	98%
3 month	96%
6 month	94%

#### Case Material

ABS UL94 HB

Option: Flammability resistance of (UL94 V-0)

#### Battery Construction

Component	Positive Plate	Negative plate	Safety valve	Terminal	Separator	Electrolyte
Raw material	Lead dioxide	Lead	Rubber	Lead	AGM	Sulfuric acid



### ⚡ Dimensions

#### Length (L)

$338 \pm_{-1}^{+2}$  (13.31 ±  $_{-0.04}^{+0.08}$ )

#### Width (W)

$173 \pm_{-1}^{+2}$  (6.81 ±  $_{-0.04}^{+0.08}$ )

#### Height (H)

$276 \pm_{-1}^{+2}$  (10.87 ±  $_{-0.04}^{+0.08}$ )

#### Overall Height (HT)

$281 \pm_{-1}^{+2}$  (11.06 ±  $_{-0.04}^{+0.08}$ )

mm(inch)

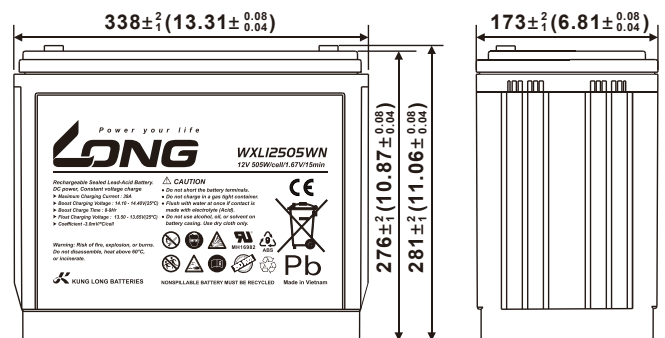
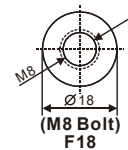
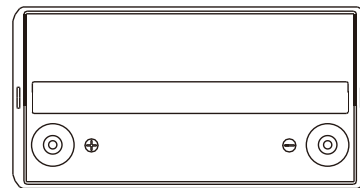

#### Terminal

F18

Recommended torque value

M8:12 N-m (122 kgf-cm)

Maximum allowable torque value

M8:20 N-m (204 kgf-cm)

#### Design Life

EUROBAT(20°C) : > 12 YEARS VERY LONG LIFE

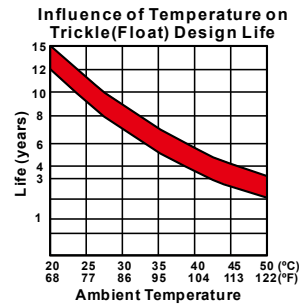
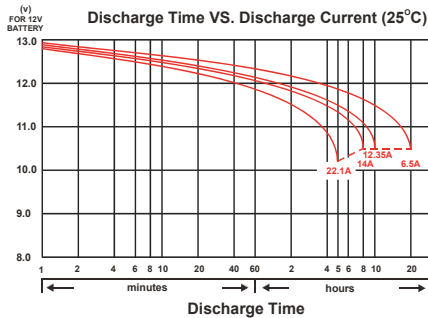
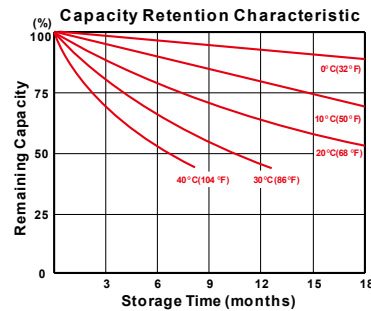
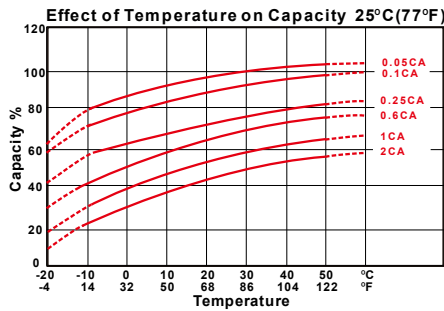

### - PERFORMANCE DATA

#### Discharge Rates in Watts to Various End Voltages at 25°C(77°F)

End Voltage		1.85V	1.80V	1.75V	1.70V	1.67V	1.65V	1.60V
2	min	703	805	900	970	1035	1095	1145
4	min	665	735	795	835	885	925	950
5	min	618	683	740	797	837	872	883
6	min	600	665	718	745	770	790	810
8	min	525	577	620	662	700	720	735
10	min	487	542	587	605	615	623	628
15	min	379	433	479	505	508	511	514
20	min	327	354	377	393	403	411	417
30	min	252	271	281	287	291	295	297
40	min	206	216	223	228	230	232	234
45	min	200	209	216	221	224	227	230
60	min	118	127	134	139	142	144	146
90	min	91.0	105	113	116	119	121	123
120	min	78.3	82.5	85.4	87.3	88.5	89.7	90.5
180	min	50.5	57.1	63.6	64.5	65.2	65.7	66.2
240	min	46.5	48.3	49.8	50.6	50.9	51.2	51.5
300	min	42.1	43.3	44.1	44.3	44.5	44.7	44.9
480	min	24.6	25.8	26.8	27.8	28.6	29.2	29.6
1200	min	12.5	12.9	13.2	13.4	13.6	13.7	13.8

### - Discharge Rates in Amperes to Various End Voltages at 25°C(77°F)

End Voltage		1.85V	1.80V	1.75V	1.70V	1.67V	1.65V	1.60V
2	min	385	462	515	560	590	620	650
4	min	350	410	465	510	532	552	572
5	min	337	392	432	462	485	500	510
6	min	312	357	397	437	460	475	485
8	min	290	325	353	367	374	379	384
10	min	267	287	305	321	337	346	352
15	min	218	235	247	257	265	270	275
20	min	172	185	194	202	207	212	215
30	min	118	125	130	136	142	147	150
40	min	101	111	118	123	124	125	126
45	min	99.2	106	111	114	116	118	120
60	min	73.4	75.1	76.3	77.2	77.8	78.4	78.8
90	min	45.4	51.6	55.5	57.7	58.9	59.7	60.5
120	min	40.0	43.3	45.8	47.1	48.4	49.1	49.5
180	min	26.5	28.4	30.1	30.6	30.9	31.2	31.5
240	min	22.8	23.2	23.5	23.8	24.0	24.2	24.4
300	min	19.8	21.0	21.7	22.1	22.3	22.4	22.5
480	min	12.5	13.4	14.0	14.2	14.3	14.4	14.5
1200	min	6.65	6.75	6.79	6.81	6.82	6.83	6.84

All data on the spec. sheet is an average value:

The tolerance range :  $X < 6\text{min}$  (+15%~-15%),  $6\text{min} \leq X < 10\text{min}$  (+12%~-12%),  $10\text{min} \leq X < 60\text{min}$  (+8%~-8%),  $X \geq 60\text{min}$  (+5%~-5%)

211124-11