

## WPL230-12N 12Volt 230Ah

### Specifications

**Nominal Voltage(V)** 12V

#### Nominal Capacity

10 hour rate (23A to 10.80V)	230Ah
5 hour rate (39.1A to 10.20V)	195.5Ah
1 hour rate (138A to 9.60V)	138Ah

**Weight** Approx. 73.2kg(161Lbs.)

**Internal Resistance (at 1KHz)** Approx. 2.5 mΩ

#### Maximum Discharge Current for

**5 seconds:** 1840A

#### Charging Methods at 25 (77 )

##### Cycle use:

**Charging Voltage** 14.4 to 15.0V

**Coefficient** -5.0mV/ /cell

**Maximum Charging Current :** 69A

##### Standby use:

**Float Charging Voltage** 13.5 to 13.8V

**Coefficient** -3.0mV/ /cell

**Design Life** 12 years

#### Operating Temperature Range

**Charge** -15 (5 ) to 40 (104 )

**Discharge** -15 (5 ) to 50 (122 )

**Storage** -15 (5 ) to 40 (104 )

#### Charge Retention (shelf life) at 20 (68 )

**1 month** 98%

**3 month** 94%

**6 month** 85%

**Case Material** ABS UL94 HB

Option: Flammability resistance of (UL94 V-0)

**Terminal** F18

#### Description of torque value of hard ware for the terminals:

**Recommended torque value** M8: 7 N-m (71kgf-cm)

**Maximum allowable torque value** M8: 9 N-m (92kgf-cm)



### Dimensions

mm(inch)

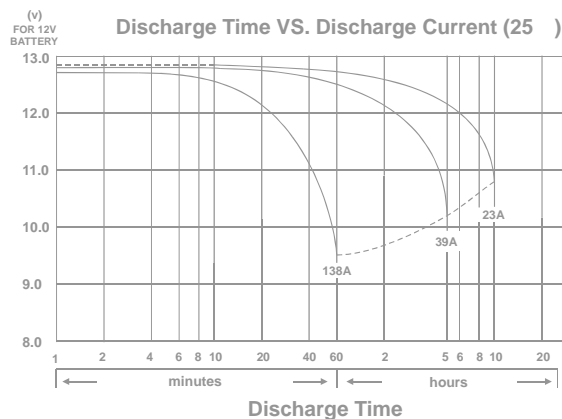
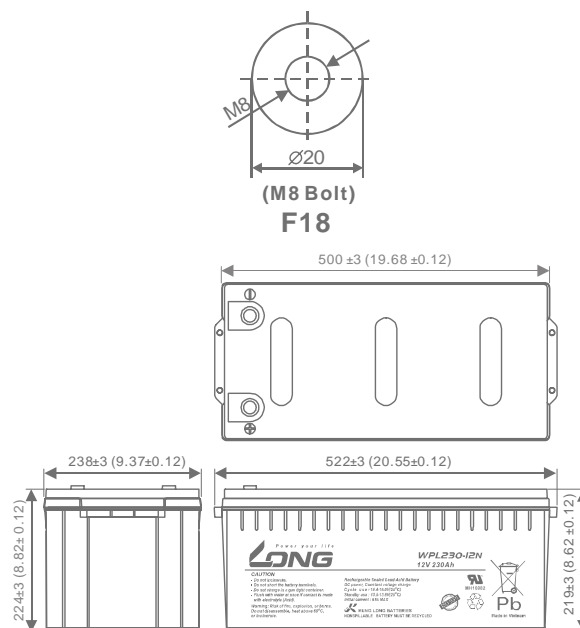

Effect of Temperature on Capacity 25 (77 )

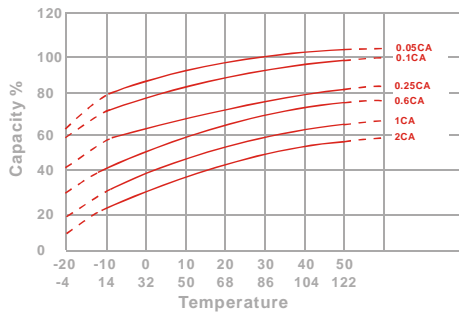

Trickle (or float) Service Life

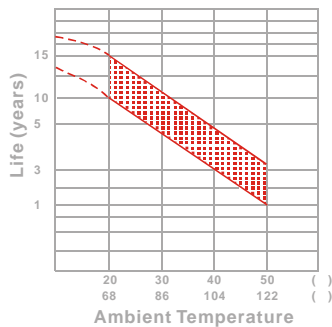

Capacity Retention Characteristic

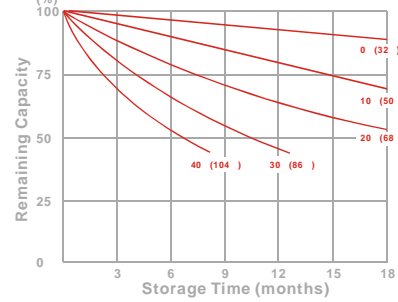

Cycle Service Life

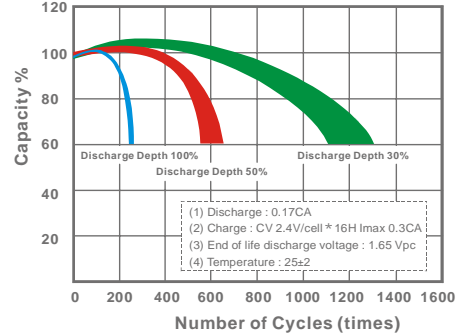

## - PERFORMANCE DATA

### Discharge Rates in Watts to Various End Voltages at 25 (77 )

End Voltage		1.85V	1.80V	1.75V	1.70V	1.67V	1.65V	1.60V
Time								
10	min	684	796	861	901	919	939	977
15	min	568	662	710	747	764	781	811
30	min	395	452	483	510	522	534	550
60	min	231	256	277	297	305	316	327
90	min	186	202	212	220	224	228	233
120	min	161	170	177	182	184	186	190
180	min	118	125	129	132	133	134	136
240	min	92.2	97.0	100	103	104	105	106
300	min	79.0	82.7	84.8	86.7	87.2	87.8	88.8
600	min	42.8	44.8	46.3	47.5	47.8	48.3	49.0
1200	min	23.2	24.3	25.0	25.5	25.7	25.8	26.2

### - Discharge Rates in Amperes to Various End Voltages at 25 (77 )

End Voltage		1.85V	1.80V	1.75V	1.70V	1.67V	1.65V	1.60V
Time								
10	min	352	403	444	476	487	502	526
15	min	316	360	389	412	421	433	447
30	min	226	252	271	285	290	296	305
60	min	124	137	148	155	158	162	168
90	min	91.6	101	107	112	113	115	119
120	min	73.4	81.5	86.2	89.6	91.1	92.8	95.1
180	min	54.5	58.6	61.3	63.7	64.4	65.2	66.9
240	min	43.8	46.4	48.5	49.9	50.5	51.2	52.3
300	min	38.1	40.5	41.9	43.1	43.5	43.0	43.8
600	min	22.3	23.0	23.3	23.6	23.7	23.9	24.1
1200	min	11.6	12.1	12.4	12.6	12.7	12.8	12.9

All data on the spec. sheet is an average value:

The tolerance range : X<6min(+15%~-15%), 6min X<10min(+12%~-12%),10min X < 60min(+8%~-8%), X 60min(+5%~-5%)

090217-11